

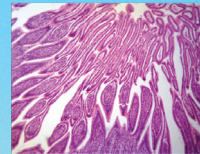

LABOMED, INC.

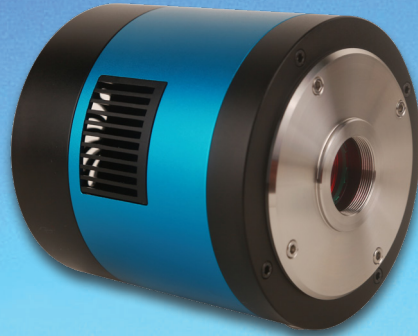

LC-22 1.4M/ICX825AQA(C) 2/3" (10.7x8.7) TE-Cooling C-mount USB3.0 CCD Camera

LC-22 1.4M/ICX825AQA(C) 2/3" (10.7x8.7) TE-Cooling C-mount USB3.0 CCD Camera adopts Sony Exview HAD CCD II sensor as the image capture device with two-stage peltier cooling imaging chip to -50 degree below ambient. This will greatly increase the signal to noise ratio and decrease the image noise. Smart structure is designed to assure the heat radiation efficiency and avoid the moisture problem. Electric fan is used to increase the heat radiation speed.

USB3.0 is used as the data transfer interface to increase the frame rate.

LC-22 1.4M/ICX825AQA(C) 2/3" (10.7x8.7) TE-Cooling C-mount USB3.0 CCD Camera comes with advanced video & image processing application ImageView; Providing Windows/Linux/OSX multiple platform SDK; Native C/C++ , C#/VB.NET, DirectShow, Twain Control API.



LABOMED, INC.

APPLICATION

The **LC-22 1.4M/ICX825AQA(C) 2/3" (10.7x8.7) TE-Cooling C-mount USB3.0 CCD Camera** can be widely used in low light environment and microscope fluorescence image capture and analysis, as well as the astronomy application.

FEATURES

The basic characteristic of **LC-22 1.4M/ICX825AQA(C) 2/3" (10.7x8.7) TE-Cooling C-mount USB3.0 CCD Camera** can be summarized as follows:

1. Standard C-Mount camera with SONY ExView HAD CCD II sensor is 1.4M;
2. Two-stage TE-cooling with controllable electric fan;
3. Image chip cooling up to 50°C below ambient;
4. Working temperature can be regulated to specified temperature in 5 minutes;
5. Smart structure to assure the heat radiation efficiency and avoid the moisture problem;
6. IR-CUT/AR coated windows;
7. Up to 1 hour long time exposure;
8. USB3.0 5Gbit/second interface ensuring high speed data transmission;
9. Ultra-Fine™ color engine with perfect color reproduction capability;
10. With advanced video & image processing application ImageView;
11. Support both video and trigger modes;
12. Providing Windows/Linux/Mac OS multiple platforms SDK;
13. Native C/C++ , C#/VB.NET, DirectShow, Twain control API.





LABOMED, INC.

SPECIFICATION

Model	LC-22
Sensor & Size(mm)	1.4M/ICX825AQA (Color) 2/3" (10.7x8.7)
Pixel(μ m)	6.45x6.45
G Sensitivity	2000mv with 1/30s
Dark Signal	4.8mv with 1/30s
FPS/Resolution	25@1360x1024
Binning	1x1
Exposure	0.07ms~1h
Other Specification	
Spectral Range	380-650nm (with IR-cut Filter)
White Balance	ROI White Balance/ Manual Temp Tint Adjustment/NA for Monochromatic Sensor
Color Technique	Ultra-Fine TM Color Engine/NA for Monochromatic Sensor
Capture/Control API	Native C/C++, C#/VB.NET, DirectShow, Twain and Labview
Recording System	Still Picture and Movie
Cooling System	Two-stage TE-cooling System -45 °C below Camera Body Temperature
Operating Environment	
Operating Temperature (in Centidegree)	-10~ 50
Storage Temperature (in Centidegree)	-20~ 60
Operating Humidity	30~80%RH
Storage Humidity	10~60%RH
Power Supply	DC 5V over PC USB Port External Power Adapter for Cooling System, DC12V, 3A
Software Environment	
Operating System	Microsoft® Windows® XP / Vista / 7 / 8 / 10 (32 & 64 bit) OSx(Mac OS X) Linux



LABOMED, INC.

PC Requirements

CPU:	Equal to Intel Core2 2.8GHz or Higher
Memory:	2GB or More
USB Port:	USB2.0 High-speed Port
Display:	17" or Larger
CD-ROM	

DIMENSION

The **LC-22 1.4M/ICX825AQA(C) 2/3" (10.7x8.7) TE-Cooling C-mount USB3.0 CCD Camera** body, made from tough, alloy with CNC technique, ensures a heavy duty, workhorse solution. The camera is designed with a high quality IR-CUT to protect the camera sensor and block the IR light. The fan's vibration is minimized to the low level to eliminate the vibration caused imaging blur. These measures ensure a rugged, robust solution with an increased lifespan when compared to other industrial camera solutions.

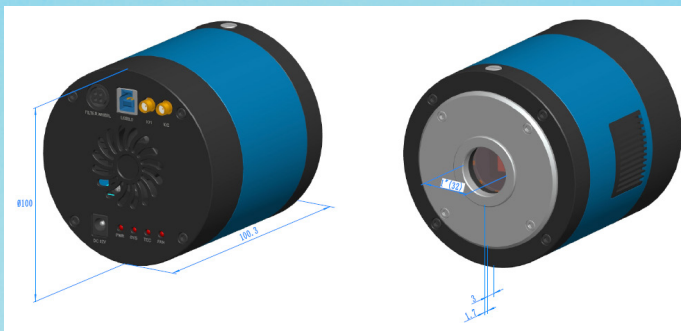



LABOMED, INC.

PACKING INFORMATION



Standard Package

- A** Carton L:50cm W:30cm H:30cm (20pcs, 12~17Kg/ carton), not shown in the photo
- B** 3-A safety equipment case: L:28cm W:23cm H:15cm (1pcs, 2.8Kg/ box);
Carton size:L:28.2cm W:25.2cm H:16.7cm
- C** LC-22 camera(C-mount)
- D** Power adapter: input: AC 100~240V 50Hz/60Hz, out: DC12 V 3A
- E** High-Speed USB3.0 A male to B male gold-plated connectors cable /2.0m
- F** CD (Driver & utilities software, Ø12cm)